

VISC - Intelligent Switch Controller

Quickly Create Custom Switch Matrixes:

- Simple Ethernet switch/attenuator control
- Configurable logical switch definitions
- Outputs directly drive 5-28V relay coils
- 56 high current, 56 TTL outputs
- Scalable to 1120 ports
- Counts switch closures to track wear
- Switch rules prevent unsafe closures
- LabVIEW and .NET drivers



VISC Supporting 112 Ports

Copyright 2007, Vektrex, Version 1.4 10/26/2007

Overview

The Vektrex Intelligent Switch/Attenuator Controller (VISC) provides a programmable interface to control RF switches and attenuators as well as other switches. Using the VISC and standard components, you can easily create custom switch matrixes and control them with simple, intuitive Ethernet commands that match your custom switch topology. The VISC has 600mA source/sink outputs that directly drive 5-28V coils, eliminating the need for external drivers or expensive TTL-control switches.

Scalable Solution

A single VISC provides 56 high current source/sink outputs and 56 TTL I/O ports. For larger applications, the VISC can be linked via an expansion bus to low-cost satellite VISCs, to provide up to 560 high current outputs and 560 TTL I/O lines.

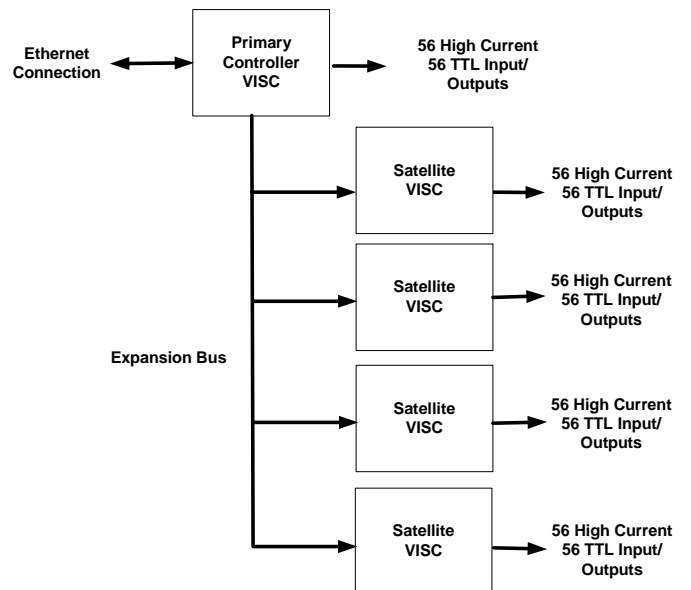

Ordering Information

Part Number	Description
Controller/Relay	
VISC-CR-5V	Controller and 56 TTL, 56 high current ports. Specify 5V or 28V maximum DC input.
VISC-CR-28V	
Satellite Relays	
VISC-R-5V	56 TTL, 56 high current ports. Specify 5V or 28V max DC input
VISC-R-28V	
Controller Only	
VISC-C-5V	Controller only. Specify 5V or 28V max DC input
VISC-C-28V	
Accessories	
VISC-terminal block	56 Position terminal block for high current or TTL ports
VISC-program cable	RS232 programming cable for TCP/IP address cable
VISC-interconnect	Expansion Interconnect Cable (ribbon) 36"

Example 5 board application: Supports 280 high current outputs and 280 TTL Inputs/outputs

Applications

- ❑ RF switch/attenuator control
- ❑ Instrumentation switch matrixes
- ❑ Custom RF switch instruments
- ❑ Large-scale RF switch matrixes
- ❑ RF test fixtures
- ❑ Remote switch control



VISC - Intelligent Switch Controller

Programming

Controlling the VISC is done with high-level “set” and “get” switch and attenuator commands. To set a switch, just identify the switch number and position. To set an attenuator, identify the attenuator number and value. If low level port access is needed (e.g. controlling display LEDs) commands to set or get the state of each port or port range are provided. To simplify application programming, drivers are provided for the LabVIEW and .NET (VB.NET, c#) environments.

Configuration

To configure the VISC, switches and attenuators are added by assigning the device number and a range of ports used. As a safety feature, if you have low-power switches that require source signals controlled by high-power switches to be in attenuated positions to avoid burn-out, switching rules can be configured that will ensure that these source switches are in proper position during switching. The configured switch attenuator positions, as well as default switch, attenuator, and port values can be saved in non-volatile FLASH memory as new power-up values.

Other Functions

Additionally, switch-wear monitoring and TCP/IP address programming is provided. To monitor switch wear, a transition count for each switch is maintained in non-volatile memory that can be retrieved and reset. The controller’s TCP/IP address can be configured either via DHCP server or set in FLASH via an RS-232 port on the VISC card.

Connections

The VISC is powered from 5-28V DC. An on-board DC-DC converter regulates this input for the internal logic and the TTL I/O ports. Two additional DC power inputs are provided for the high current relay driver circuitry; these inputs should be connected to the appropriate voltage for the relay coil being driven, 12V, 24V, 28V, etc. To drive TTL relays, 5V should be used.

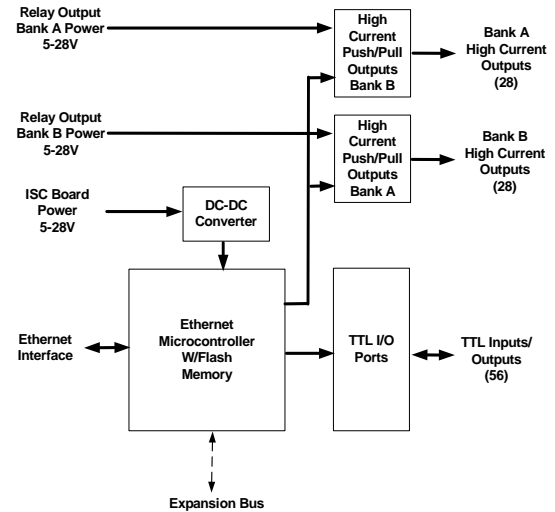

Connection Diagram

Specifications

Size:	5.5 inches x 4 inches x 1.2 inches
Ports:	56 high current (2 banks of 28, output only) 56 TTL (input/output)
Port Configuration:	Sourcing or Sinking, configurable with jumpers and commands
Input Power:	8-28V for VISC, 5 W typical 5-28V for high current outputs
High Current Outputs Current:	600mA max for any output 5A maximum per bank
High Current Output Saturation Voltage:	0.6V off ground or voltage rail for 5mA load (TTL) 1.2V typical, 1.8V max for 600mA
TTL Output Current:	2mA source min, 10mA sink
Expansion Bus:	20 pin ribbon cable, 10 foot max.
IP Address:	DHCP default, optional fixed address, settable with serial cable
I/O Connectors	60 pin ribbon header, optional terminal block
Power Connector	Phoenix 6 pin right angle terminal



For more information see www.vektrex.com
Contact melissa@vektrex.com: Melissa Ford
Phone: (858) 558-8282 x6