

# Laser Diode Power Supply Transient Response Under Typical Laser Diode Fault Conditions

Vektrex April, 2007

**Abstract – This paper discusses typical multi-laser drive topologies used in burn-in or life testing applications and presents possible laser failure mechanisms that can challenge power supplies driving the lasers. A typical laser failure scenario is then proposed – a gradual increase in laser impedance followed by a sudden drop in impedance. A test circuit consisting of six lasers and a MOSFET transistor is constructed and this circuit is used to test how three laser diode power supplies respond in this scenario. Observed voltage and current spikes produced by the supplies are presented and the excess power and energy delivered to the lasers is calculated.**

## INTRODUCTION

Semiconductor laser diodes are often tested under elevated stress conditions to accelerate the aging process and expose failures. These test operations typically involve quantities of devices in order to get a statistically significant measure of the device's failure rate.

The drive electronics powering the lasers during these tests are usually optimized for cost, size, and efficiency. Often several lasers share a common power supply. This arrangement reduces cost and complexity, but it requires the power supply current or voltage capability to be sized at  $n \times$  the nominal voltage or current, where  $n$  is the number of lasers being powered.

When a laser fails, it presents an abnormal load to the supply. This change can shift the voltage or current to levels well above the normal operating level for a single laser. When this happens, the failing laser can suffer catastrophic damage, and other lasers in the circuit may see an abnormal stress level and possibly suffer damage. To preserve failed devices as much as possible for failure analysis, and to prevent secondary device failures, well-regulated or protected power supplies that minimize this effect are essential.

This paper documents tests with three types of power supplies to determine how they respond to a typical failure scenario in a six-laser circuit.

## BACKGROUND – TYPICAL LASER FAULTS:

In monitoring the parameters of laser devices, the measurement of light emission and current flowing through the device are two of the more important parameters. The emission of light from the laser device is directly related to the current passing through the device.

### Preferred Drive Topology – Series Circuit With Constant Current Control

In many cases, multiple laser diodes are placed in series or parallel circuits for burn-in or life testing of the devices. Placing devices in parallel adds a bit more complexity to the testing due to the variations in the devices. In a parallel scheme the current can vary from branch to branch due to the variation in impedance of each branch, so each branch requires adjustment in order to maintain equal flow of current. To avoid this, a simple way to ensure equal current through all the devices is to use a series topography along with a power supply that offers constant current control.

With the devices in series, there is one branch, and the current is the same through each device. This allows for direct comparison of each Device Under Test's (DUTs) light output based on the current. A downside of this configuration is the possibility of a device failing in an open circuit. At this point the testing is over for all the devices in series with the failed part. Even with this drawback, the series circuit is usually preferred – its success relies upon the ability of the power supply to manage current through the circuit at a constant level, regardless of the voltage across the DUTs.

## Laser Failures – Impact Forward Voltage Drop

There are number of observed laser diode defects at both the device and packaging level that require careful consideration in the choice and brand of constant current power supply used. Some typical defects in laser diodes that eventually lead to thermal runaway and failure, ending in an open or short circuit, are:

- ❑ Dark line defects
- ❑ Dark spot defects
- ❑ Emitter cavity defects
- ❑ Front facet defects
- ❑ Stress related cracks in the laser bar
- ❑ Solder migration
- ❑ Solder voids

Thermal runaway will initially cause the voltage drop across the device to decrease, but as the failure continues, the voltage will rise due to the increase in contact resistance. As the contact resistance increases, the temperature will rise, inducing electromigration of the solder between the laser bar and submount. This migration will in turn create larger voids between the bar and the submount, further elevating the contact resistance. As the cycle continues, a point at which the solder liquefies will be reached, initiating a catastrophic failure.

## Sudden Voltage Shifts Challenge Power Supply Current Control

For a current controlled power supply, as the voltage rises, the supply will increase the voltage potential to maintain its set current value. At some point the laser bar will break down due to the failure mentioned above, in either an open or short circuit. A short across the device will cause a sudden shift in the forward voltage, forcing the power supply to transition rapidly to a new operating point. To make this transition, the power supply has to dump the energy stored in its output capacitors and transition its control loop. During this transition, excess energy is delivered to the load in the form of a current spike through all the devices sharing the series circuit. If the power supply possesses the circuitry to adjust and compensate in less than a few milliseconds, little or no damage may occur to the other good laser diodes. But if the circuitry in the supply is slow to respond or is absent, then there is a high probability that all the devices in the series circuit including the good devices will suffer damage.

## EXPERIMENTAL SETUP:

To simulate a failing laser's gradual increase in impedance followed by a sudden drop, the setup in Figure 1 was used.

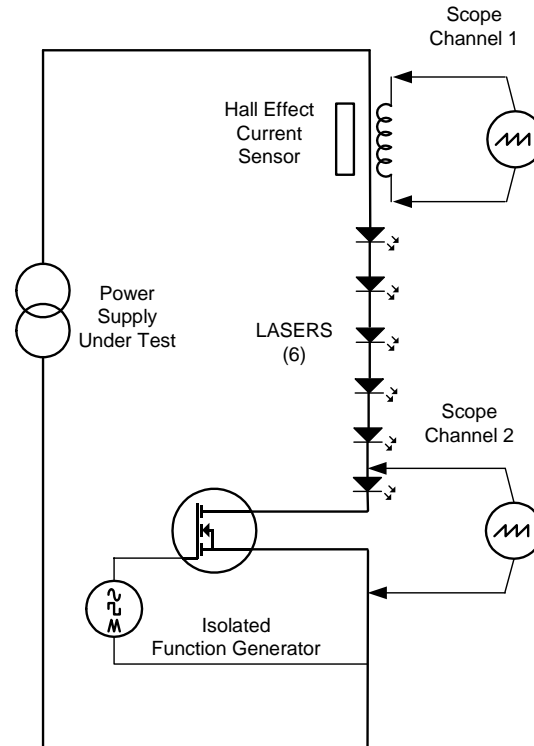
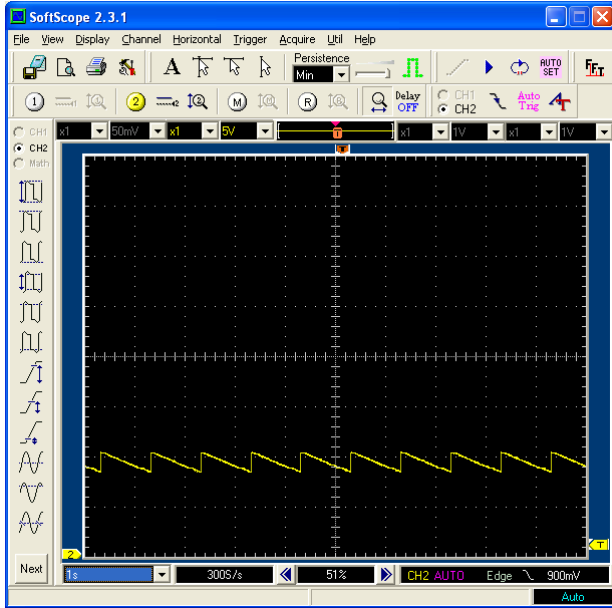

Figure 1 - Experimental Setup

In this setup the power supply under test was arranged to drive six CCP-type lasers; the lasers were mounted on a water-cooled plate and the laser outputs were directed to a water-cooled beam dump. The circuit included a 200:1 hall-effect AC/DC current sensor to measure the current through the lasers and an 10:1 isolated oscilloscope probe to measure the voltage across the MOSFET/laser pair. The MOSFET was driven with an inverted saw tooth waveform as shown in Figure 2.



**Figure 2 - MOSFET Drive Waveform**

**Ch 2 - 5V/div, 1S/div**

By adjusting the frequency and lower end point of this waveform the MOSFET was driven from saturation, to the linear region and then rapidly back into saturation. For this testing a frequency of roughly 2Hz and a lower voltage of roughly 3.2V was used.

This action resulted in an increasing ramp voltage waveform across the last laser as shown in Figure 3. The amplitude of this rising voltage varied from a few volts for the SpikeSafe current source<sup>1</sup> to 20-60 volts for one of the tested supplies. The increasing ramp terminated in a sharp drop. This drop induced a current spike through the laser string as shown in the top trace of Figure 3.

<sup>1</sup> The SpikeSafe current source would not allow the output voltage to rise more than a few volts from nominal before it declared an error and shut down.

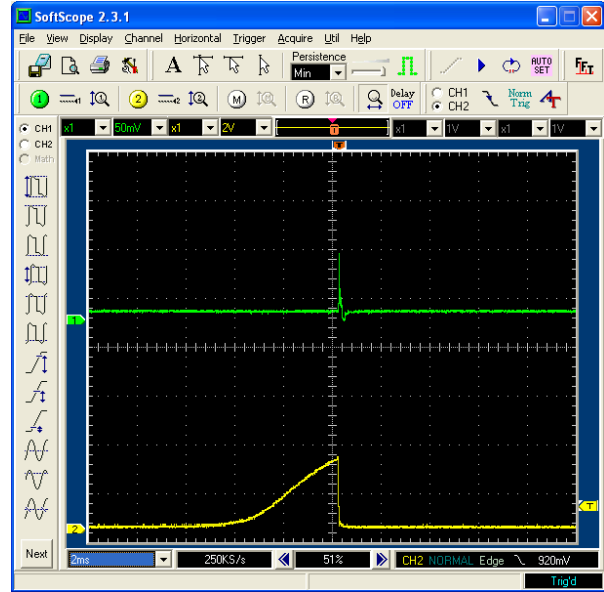

**Figure 3 – MOSFET/Laser Current & Voltage**

**Ch 1 – 10A/div, Ch 2 - 20V/div, 1S/div**

**Equipment Used:**

The following equipment was used for this test:

Manufacturer	Model, Description
Agilent	33250A 80MHz function generator
SoftDSP	SDS200A dual channel 200MHz USB oscilloscope
LEM	LA150P hall effect current sensor
Coherent	CCP 808nm lasers
IXYS	XFK 110N06 MOSFET

**Table 1 - Equipment Used**

**TESTED POWER SUPPLIES:**

Three types of power supplies were tested in this experiment. The first, Supply 1 60-100 is a simple laboratory adjustable supply that was operated in constant current mode. This type of supply usually includes a significant output capacitance and a control loop operating in the millisecond range.

The second, Supply 2, an special purpose current source, is designed for current output only. This has very little output capacitance and a fast control loop with response in 10s-100s of microseconds, however it lacks overvoltage

protection circuits or algorithms to handle fault conditions

The third, a Vektrex SpikeSafe 200 current source which uses a two-stage regulation scheme that has a response time in the 2-5 microsecond range. The SpikeSafe 200 also includes several protection features to shut off drive in the event of an anomaly. One of these is dV/dt protection. This protection feature shuts off drive if an abnormal rise or fall in forward voltage is detected. For this experiment, dV/dt detection was disabled.

Manufacturer	Model, Description
Supply 1	General purpose lab supply 60V, 100A
Supply 2	60V, 167A, High slew rate, low capacitance supply
Vektrex	SpikeSafe 200 100V, 120A Spike protected supply

**Table 2 - Supplies Tested**

Supply	Type	Protections
Supply 1	Lab, voltage output	Overvoltage
	mS response	Overcurrent
Supply 2	Low Capacitance	Overcurrent
	20-100uS response	
Vektrex	Two stage regulation	Overvoltage
		Overcurrent
	3-5uS response	dV/dt
		Current anomaly
		Dynamic compliance voltage limitation

**Table 3 - Supply Features**

**TEST RESULTS:**

**Supply 1:**

Supply 1 was tested using the experimental setup at 10A and 20A. The supply's voltage setting was adjusted to a few volts above the nominal to limit the rise in compliance voltage; and for two of the tests, over voltage protection was enabled. The 10A result without over voltage protection is shown in Figure 4. Trace 2 shows that prior to the sudden decrease in impedance, the forward voltage across the MOSFET/laser pair had risen to roughly 4.5V. This was high enough to drive the supply into constant voltage mode, reducing the current delivered to roughly 4A. When the transition to low impedance occurred, the current spiked up to 52A, and then recovered to the 10A set point in 3mS.

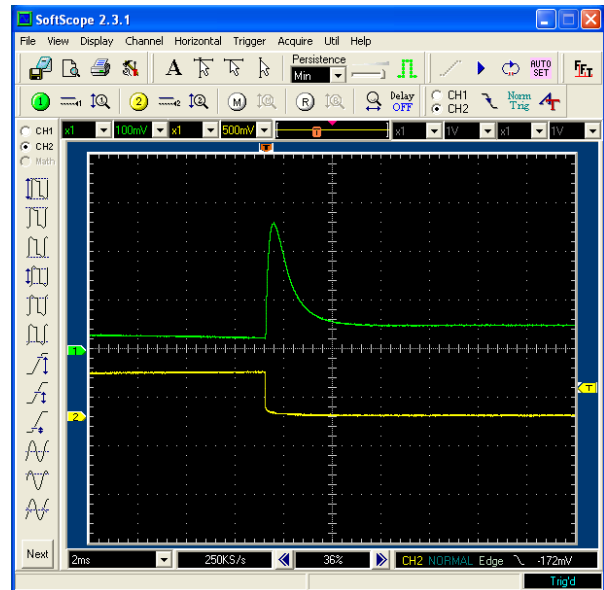
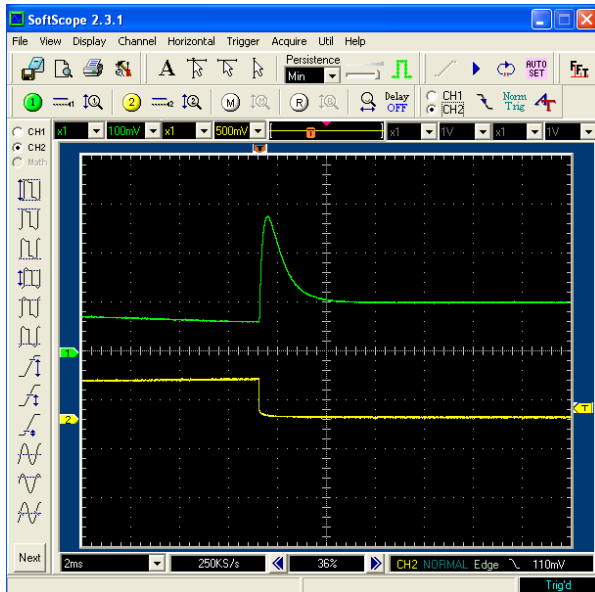

**Figure 4 – Supply 1 High/Low 10A**

**Ch 1 – 20A/div, Ch 2 – 5V/div, 2mS/div<sup>2</sup>**

In Figure 5 the 20A result is shown. The 20A result was very similar to the 10A test, with the current spiking to 56A before recovering to the set point. Figure 6 and Figure 7 show 20A tests with the Supply 1's over voltage protection set to prevent a large buildup of forward voltage. With over voltage protection enabled, the supply shut off before the transition to low impedance could occur.

<sup>2</sup> Some of the oscilloscope captures incorrectly used the x1 voltage scale setting, thus the actual v/div is 10x the value shown in the screen capture.



**Figure 5 – Supply 1 High/Low 20A**

**Ch 1 – 20A/div, Ch 2 – 5V/div, 2mS/div**

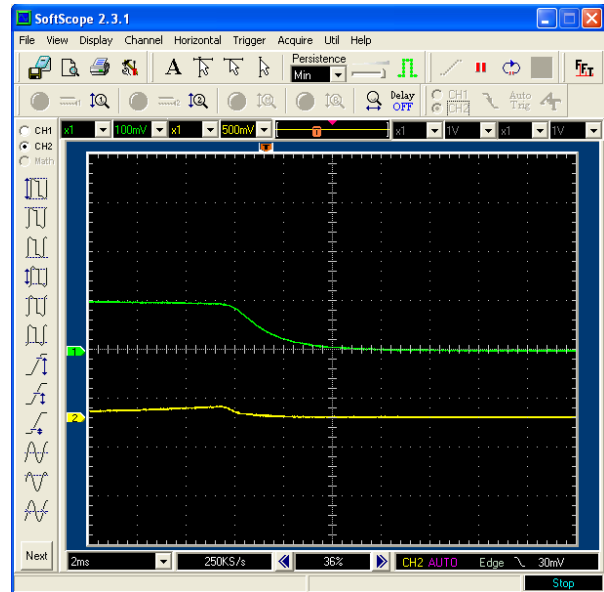

**Figure 7 - Supply 1 High/Low 20A, 7.9V OVP**

**Ch 1 – 20A/div, Ch 2 – 5V/div, 2mS/div**

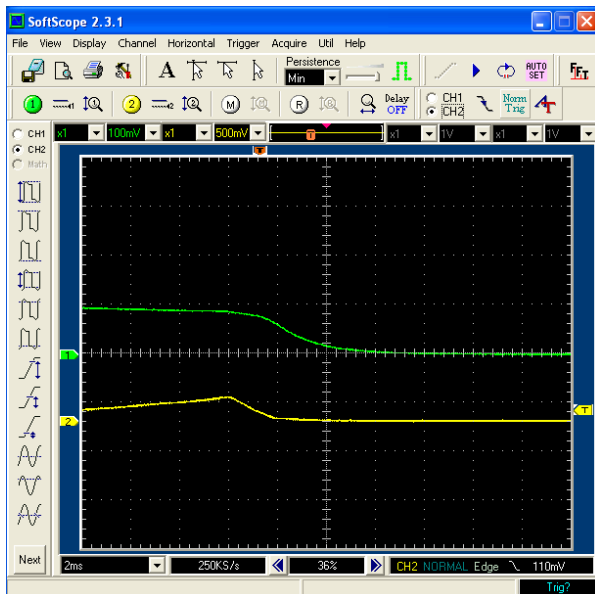
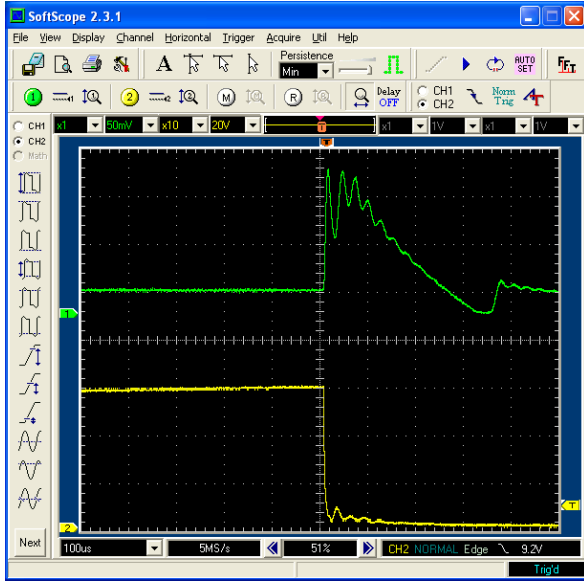

**Figure 6 - Supply 1 High/Low 20A, 9V OVP**

**Ch 1 – 20A/div, Ch 2 – 5V/div, 2mS/div**

**Supply 2:**

Supply 2 did not have a constant voltage mode or over voltage protection. Without the voltage limiting provided by these features, the supply increased its output voltage to the full compliance voltage during the high impedance phase of the test. Unlike the 4.5V rise of the Supply 1, this was a 45-60V rise across the MOSFET/laser pair. Then, when the transition to low impedance occurred, the current spiked upward of 20-30A above the setpoint, recovering in roughly 300-400uS. The relative amplitude of the spike was worst at 5A and fairly constant at 24A above setpoint for currents from 10A to 40A. See Figure 8 - Figure 11.



**Figure 8 – Supply 2 High/Low 5A**  
 Ch 1 – 10A/div, Ch 2 – 20V/div, 100uS/div

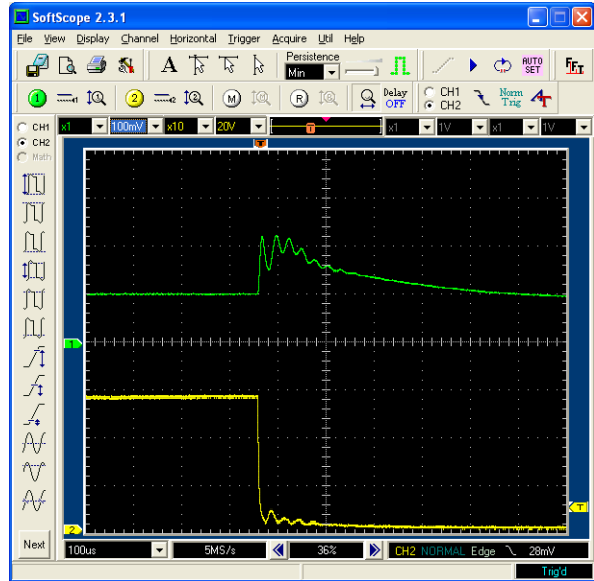

**Figure 10 – Supply 2 High/Low 20A**  
 Ch 1 – 20A/div, Ch 2 – 20V/div, 100uS/div

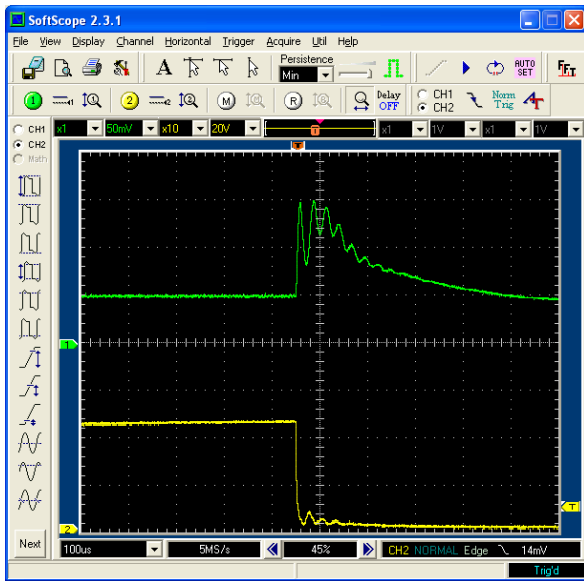

**Figure 9 – Supply 2 High/Low 10A**  
 Ch 1 – 10A/div, Ch 2 – 20V/div, 100uS/div

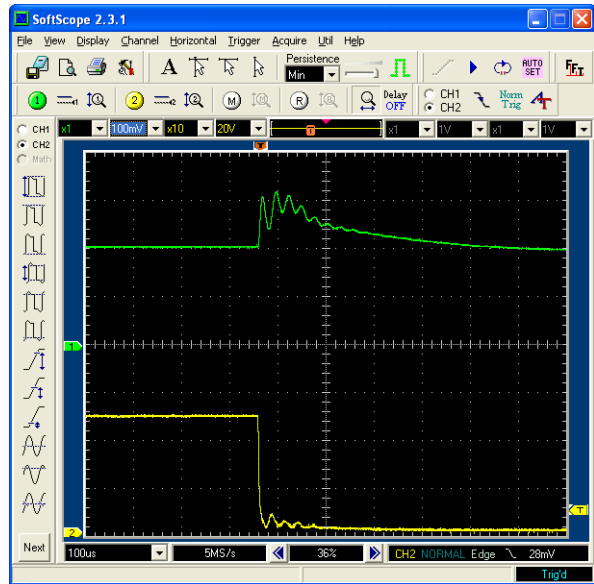

**Figure 11 – Supply 2 High/Low 40A**  
 Ch 1 – 20A/div, Ch 2 – 20V/div, 100uS/div

## Vektrex SpikeSafe 200:

The SpikeSafe 200 was tested at 10A and 20A. For this testing dV/dt detection was disabled, as it would have shut off the output before the low impedance portion of the test. Initially the same MOSFET drive conditions were used as those used for Supply 2, however it was found that that even with dV/dt detection disabled, the SpikeSafe unit would shut down with an over voltage fault under these conditions. To overcome this, the MOSFET drive waveform was adjusted to reduce the rise in forward voltage to roughly 3V above nominal. Under these conditions current remained on during the low impedance portion of the test. With the new setting, the SpikeSafe produced a current spike 4-8A above the setpoint with duration of roughly 20uS. See Figure 12 - Figure 13. After testing at 10A and 20A, the SpikeSafe's over current setting was adjusted to its most sensitive setting, and the 20A test was repeated. With the lower trip point, the power supply shut off when the MOSFET transitioned to low impedance. See Figure 14.

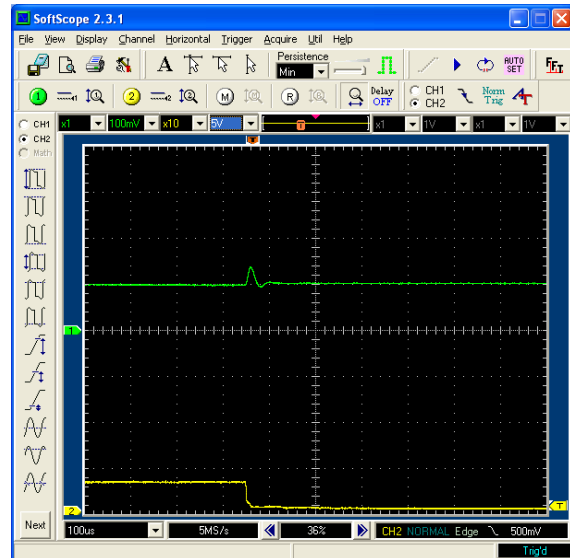

Figure 13 - SpikeSafe High/Low 20A

Ch 1 – 20A/div, Ch 2 – 5V/div, 100uS/div

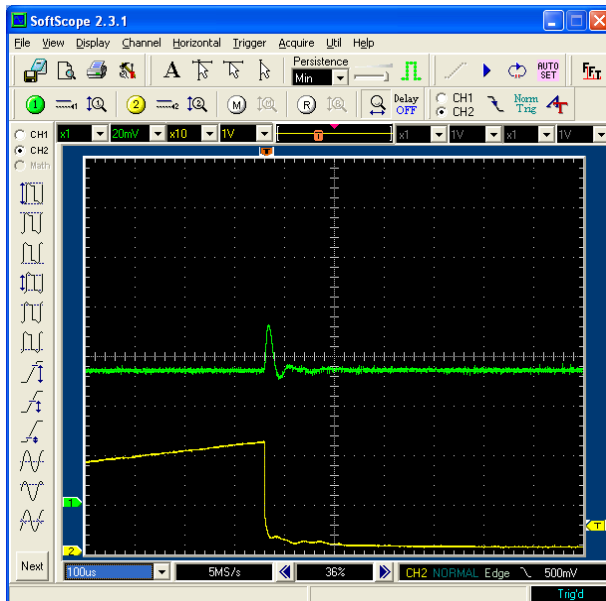

Figure 12 - SpikeSafe High/Low 10A

Ch 1 – 4A/div, Ch 2 – 1V/div, 100uS/div

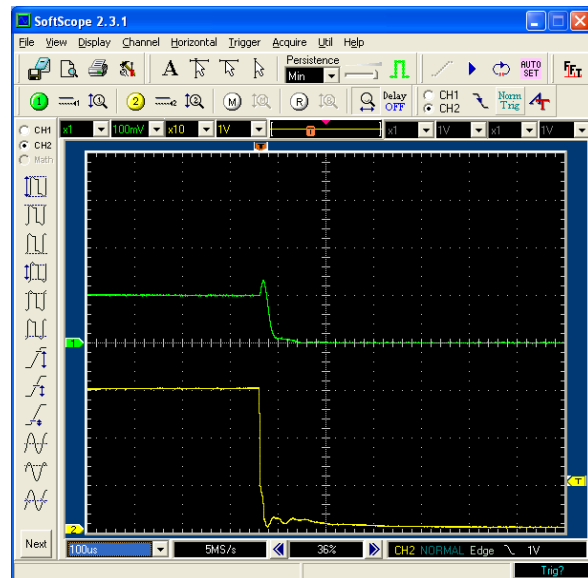

Figure 14 - SpikeSafe High/Low 20A With Over Current Trip

Ch 1 – 20A/div, Ch 2 – 1V/div, 100uS/div

**ANALYSIS:**

In this type of laser fault, with its characteristic increased forward voltage followed by a current spike, the laser exhibiting the fault is subjected to increased forward voltage stress, while the faulty laser and the other lasers in the series circuit are subjected to the excess current stress. See Table 4, below.

Fault Characteristic	Stress On Laser With Fault	Stress On Other Lasers In Circuit
Increased Forward Voltage	Excess voltage	No increased stress
Current Spike	Excess current	Excess current

**Table 4 - Laser Stresses**

**Excess Voltage Stress:**

Excess voltage can cause breakdown within the faulty laser; it also increases power dissipation in the laser. This increased power dissipation occurs in the region of the laser with the fault, so it contributes to the thermal runaway.

Supply 2 produced a significant excess voltage as the supply often rose close to the full 60V+ compliance during the high impedance portion of the fault. For the 20A test case, the peak power dissipation was:

$$20A \times 56V = 1120W$$

Since the nominal power is 20W, this was 1100W above normal. This rise to 56V took roughly 1.5S so the excess energy delivered was:

$$1100W \times 1.5S \times 0.5 = 825J$$

This is 795J above 30J, the normal energy delivered in 1.5S.

The Vektrex and Supply 1 units did not allow the voltage to rise more than a few volts above the nominal value, and so they had much lower power dissipation during this phase of the fault. For the Vektrex supply:

$$20A \times 3V = 60W$$

This was only 40W above nominal. The excess energy delivered was:

$$40W \times 1.5S \times 0.5 = 30J$$

**Excess Current Stress:**

Excess current can damage lasers directly, or it can induce damage because of excess power dissipation. For the supplies tested, the excess current portion of the fault lasted from 20uS (Vektrex), to 3mS (Supply 1). Under these conditions the excess power was probably not significant, but the amplitude of the excess current was. For the 20A testing, the Supply 1 unit exhibited the worst performance with a 56A peak current. Supply 2 was slightly better with a 44A peak and the Vektrex supply performed best with a peak at 28A, only 8A above nominal. See Table 5 below.

Supply	Peak Current	% Increase
Supply 1	56A	180%
Supply 2	44A	120%
Vektrex	28A	40%

**Table 5 - Current Spike Amplitude At 20A Nominal**

**CONCLUSION:**

When lasers are operated in series circuits for burn-in or life testing, the power supply driving the lasers can significantly alter the risk of damage from the abnormal voltage and current stresses. This testing showed that the risk of damage when using the SS200 supply to drive laser diodes in series circuits is significantly lower than either the Supply 1 or Supply 2. This is not to say that these units are not of good quality, but rather to point out the limits of the capabilities of these types of supplies when used to drive laser diodes during life test and burn-in.